

TOCOS[®] AMERICA INC. Surface Mount Trimming Potentiometers



G32 Series Specifications

Part Number Determination

G32ATB102M						
G32	1	A	T	B	102	M
SERIES	ADJUSTMENT SLOT	TERMINATION STYLE	PACKAGING	RESISTANCE TAPER	RESISTRANCE	TOLERANCE
G32=3mm Sq. 1-Turn, RoHS Compliant	1=Cross-Slot Automatic Adjust Blank=Single-Slot	A=J-Hook B=Gull-Wing	T=Tape & Reel Blank=Bulk	B=Linear	2 Significant Digits + Multiplier 100=10ohm 102=1Kohm 105=1Mohm	M=±20%

Package Dimensions (in/mm)

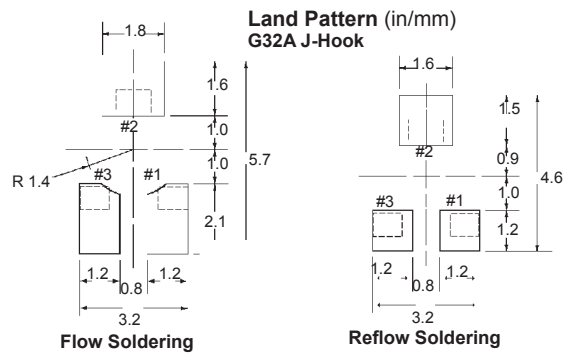
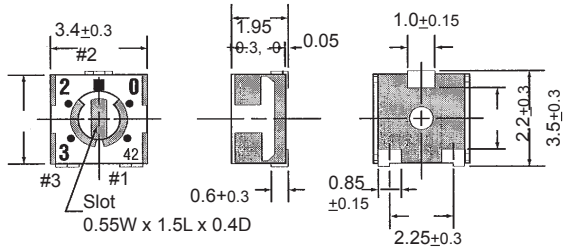

Package Dimensions (in/mm)

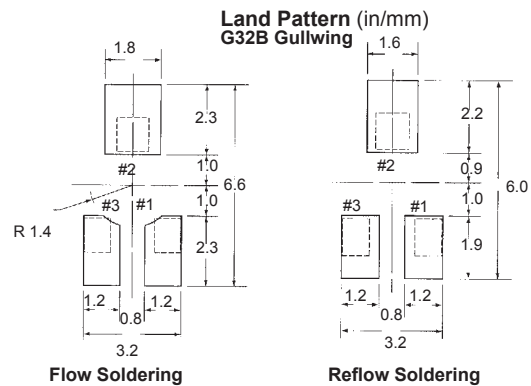
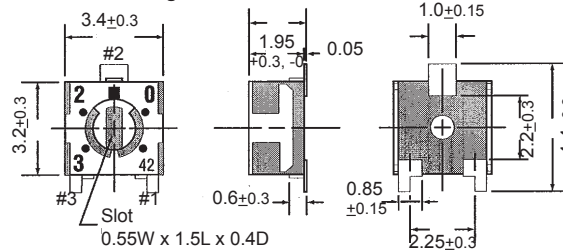

Schematic

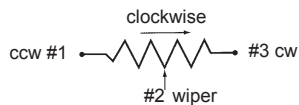

Value/ Part Number Code

Value (ohms)	50	100	200	500	1K	2K	5K	10K	20K	50K	100K	200K	500K	1M	2M
Part # code	500	101	201	501	102	202	502	103	203	503	104	204	504	105	205